

1.5MHz, 3A, High Efficiency PWM Step-Down DC/DC Converter

General Description

The ID8225A is a high-efficiency, DC-to-DC step-down switching regulator, capable of delivering up to 3A of output current. The devices operate from an input voltage range of 2.7V to 5.5V making the iD8225A ideal for low voltage power conversions. Running at a fixed frequency of 1.5MHz allows the use of small inductance value and low DCR inductors, thereby achieving higher efficiencies. Other external components, such as ceramic input and output caps, can also be small due to higher switching frequency, while maintaining exceptional low noise output voltages. Built-in EMI reduction circuitry makes this converter ideal power supply for RF applications. Internal soft-start control circuitry reduces inrush current. Short-circuit and thermal-overload protection improves design reliability.

iD8225A is housed in a tiny TDFN-8L package.

Ordering Information

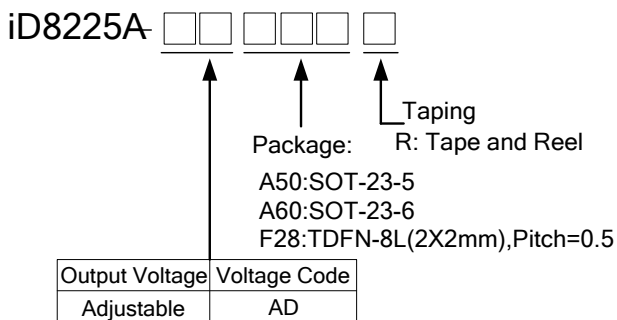

Applications

- USB ports/Hubs
- Hot Swaps
- Cell Phones
- Tablet PC
- Set Top Boxes

Features

- Up to 3A Max Output Current
- 2.7V to 5.5V Input Voltage Range
- Fixed 1.5MHz Switching Frequency
- Light Load Operation
- 100% Duty Operation
- Internal Compensation
- RoHS Compliant and Halogen Free
- Tiny TDFN-8L Package

Marking Information

For marking information, please contact our sales representative directly or through distributor around your location.

Typical Application Circuit (Adjustable Operation)

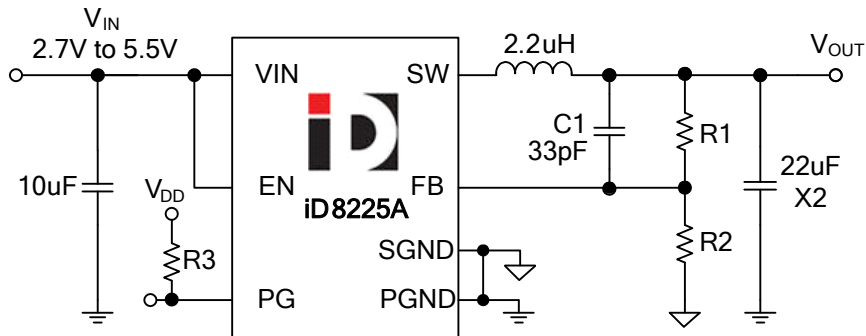

Absolute Maximum Ratings (Note 1)

VIN Voltage	-0.3V to 7 V
SW, FB, EN, PG Voltage	-0.3V to 6 V
Power Dissipation, P_D @ $T_A=25^\circ\text{C}$	
SOT-23-5	600mW
SOT-23-6	600mW
TDFN-8L	1282mW
Thermal Resistance, θ_{JA}	
SOT-23-5	167°C/W
SOT-23-6	167°C/W
TDFN-8L	78°C/W
Lead Temperature	260°C
Storage Temperature	-65°C to 150°C
Thermal Resistance, θ_{JC}	
SOT-23-5	130°C/W
SOT-23-6	110°C/W
TDFN-8L	20°C/W

Recommended Operating Conditions

Input Voltage V_{IN}	2.7V to 5.5V
EN Input Voltage	0V to V_{IN}
Junction Temperature	-40°C to 125°C
Ambient Operating Temperature	-40°C to 85°C