

18V, 3A, High Efficiency Synchronous Step-Down Converter

General Description

ID8721 is a wide input range, high-efficiency and high frequency DC-to-DC step-down switching regulator, capable of delivering up to 3A of output current. With a fixed switching frequency of 500KHz, this current mode PWM controlled converter allows the use of small external components, such as ceramic input and output caps, as well as small inductors. ID8721 also employs a proprietary control scheme that switches the device into a power save mode during light load, thereby extending the range of high efficiency operation. An OVP function protects the IC itself and its downstream system against input voltage surges. With this OVP function, the IC can stand off input voltage as high as 19V, making it an ideal solution for industrial applications such as LCD TV, Set Top Box, Portable TV, etc.

ID8721 is available in FCTSOT23-6 package.

Ordering Information

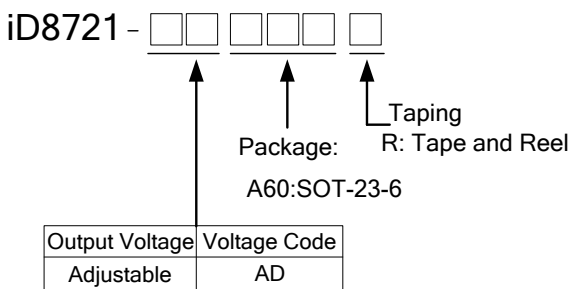

Applications

- LCD TV
- Set Top Box
- Portable TV

Features

- Wide Input Range: 4.2V-18V
- High Efficiency with PFM mode at Light Load
- Capable of Delivering up to 3A Current
- No External Compensation Needed
- Current Mode Control
- Thermal Shutdown and UVLO
- Available in SOT23-6 Package

Marking Information

For marking information, please contact our sales representative directly or through distributor around your location.

Typical Application Circuit

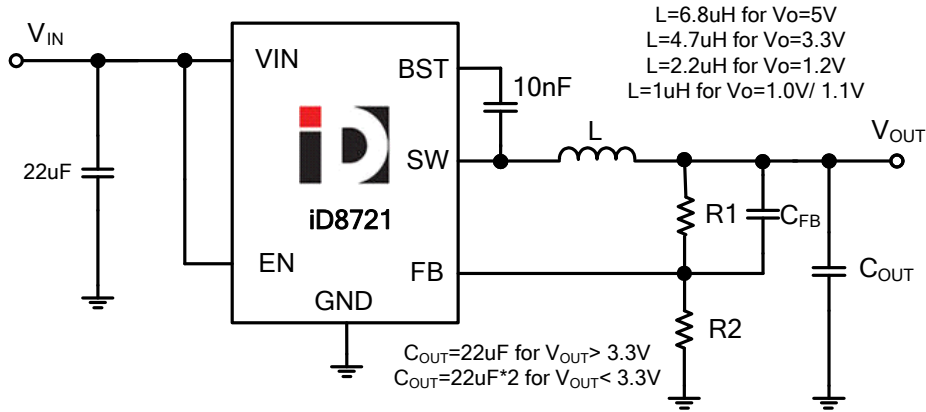

Absolute Maximum Ratings

V_{IN} , SW, EN	-0.3V to 19V
BST Voltage	-0.3V to SW + 6V
FB Voltage	-0.3V to +6V
Power Dissipation, P_D @ $T_A=25^\circ\text{C}$	
SOT-23-6	1W
Thermal Resistance, θ_{JA}	
SOT-23-6	100°C/W
Thermal Resistance, θ_{JC}	
SOT-23-6	55°C/W
Lead Temperature	260°C
Storage Temperature	-55°C to 150°C
ESD HBM (Human Body Mode)	2KV
ESD MM (Machine Mode)	200V

Recommended Operating Conditions

Supply Voltage V_{IN}	4.2V to 18V
Junction Temperature	-40°C to 125°C
Ambient Operating Temperatures	-40°C to 85°C